

CANTONI
MOTOR

www.cantonigroup.com



SERVICE INSTRUCTION MANUAL FOR SQUIRREL - CAGE INDUCTION MOTOR TYPE

(2,3,4)SIE 200 ÷ 315 A,B,C,D

(2,3,4)SIEK 200 ÷ 315 A,B,C,D

(2,3,4)SIEL 200 ÷ 315 A,B,C,D

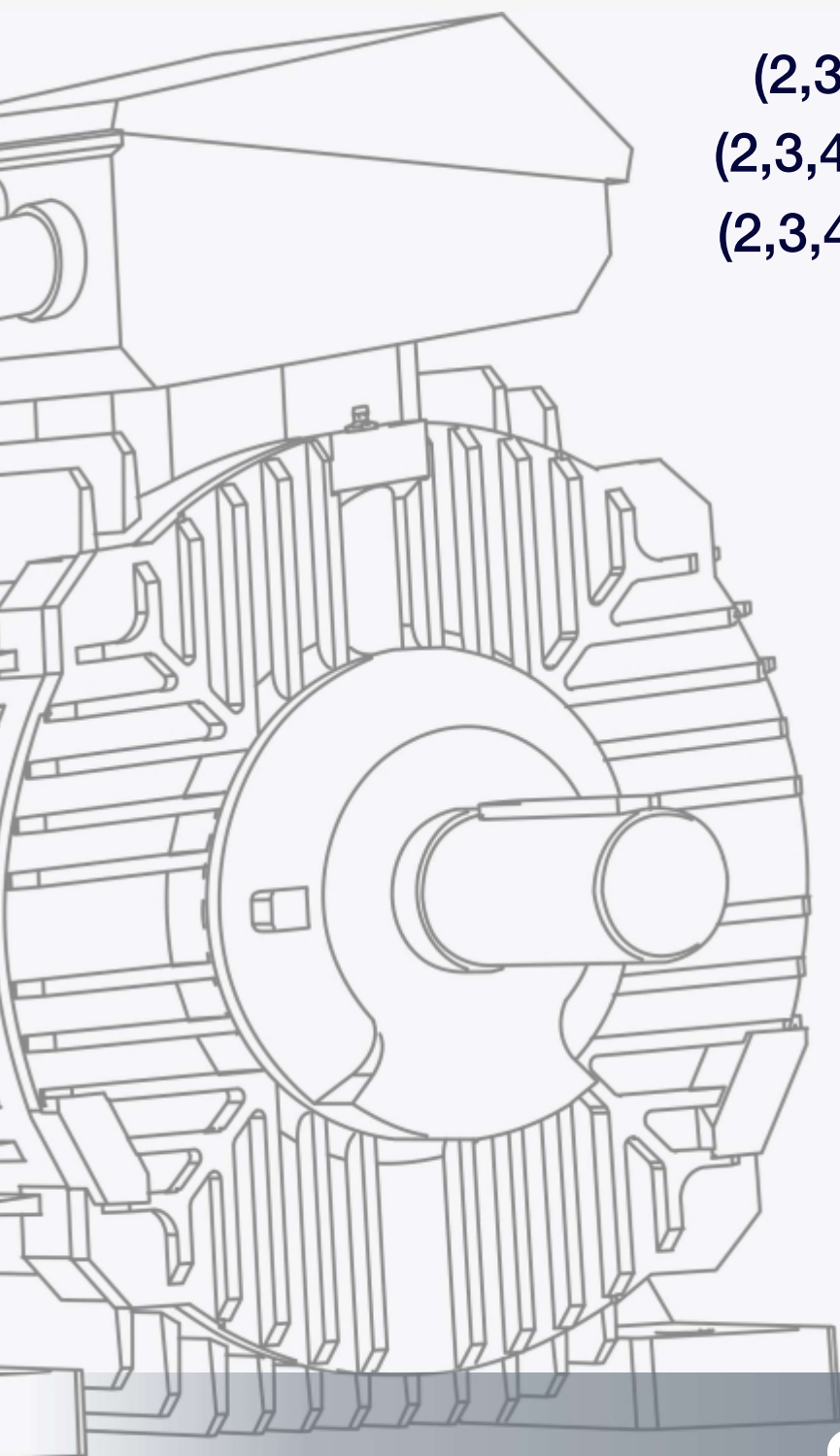

Cantoni[®]
GROUP

OPERATING MANUAL

1. SPECIFICATION

GENERAL INFORMATION

Motors with parameters according to the data sheet comply with the requirements of the IEC 60034-1 standard, and IEC 60034-30-1 class efficiency IE2, IE3 or IE4.

Motor versions:

- on mounting feet - motor size 200÷315 - type marking (2,3,4)SIE
- flange-type - motor size 200÷315 - type marking (2,3,4)SIEK
- on mounting feet with a flange - motor size 200÷315 - type marking (2,3,4)SIEL

OPERATING CONDITIONS

Voltage variance:	± 5%
Ambient temperature:	-30 °C do + 40°C
Relative air humidity at 25° C	100%
The inclination of the shaft axis to the level:	0° ÷ 90°
Type of operation:	S1 /continuous/
Altitude of motor installation	up to 1000 m

PROTECTION RATING

Motors in a basic version have a protection rating IP55 acc. to PN- IEC 60034-5.
On request, motors can be made with a protection rating IP66.

CASING

The motor's casing (body, bearing brackets) and the terminal box are cast in grey cast iron. Ventilator cover is made of sheet steel.

Air intake grate has dimensions guaranteeing protection rating IP20.

WINDING, INSULATION

Stator winding and the insulation material used correspond to the insulation class F. On request, motors can be made with insulation class H. Thermal protection (posistors) is installed the stator winding. The squirrel-cage is cast in aluminium.

Version made upon request:

- resistance thermometers Pt100 installed in the winding
- heating elements (motor's internal protection at standstill against condensation)

Information:

Resistance and temperature specifications of the PTC thermistor / posistor/.

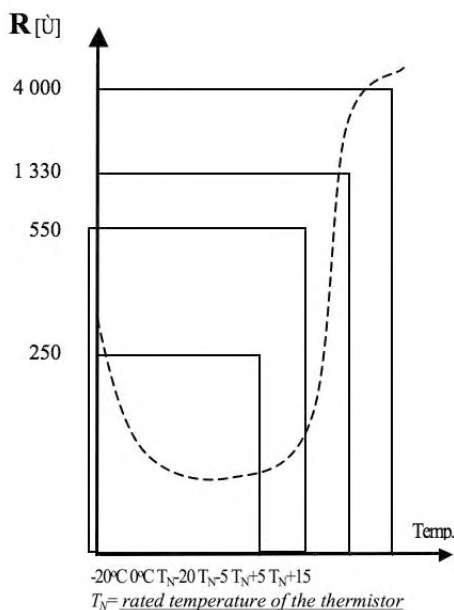

Resistance [Ω]	Temperature [°C]
from 20 to 250	from 20 to TN-20
<550	TN-5
>1 330	TN+5
>4000	TN-15

BEARING MOUNTING

For mounting the rotor bearing, rolling bearings have been used. Assignment of bearings to particular motor sizes is listed in Table no. 1.

Motors are equipped with grease nipples allowing for adding grease to the bearings.

On request - bearing brackets adapted for installation of thermal protection and vibration sensors.

TERMINAL BOX

The terminal box is located at the top of the motor.

Construction of the terminal box allows for setting the cable inlets at an angle of 90° or 180° from the original position.

Motors in the basic version have 6 current terminals (terminal board) in the terminal box, and two auxiliary terminals - block LZ4. In the version made on request, motors with winding heaters have an additional terminal block in the terminal box. Markings of the terminals and the diagram of connections is shown in the table containing the connection layout located on the cover of the terminal box.

SAFETY TERMINALS

The terminal for the safety conductor is located inside the terminal box. Additional external terminal for connecting an earthing cable is located on the motor's casing.

MOTOR DRAINAGE

Motors have openings in bearing brackets for draining the inside of the motor.

2. TRANSPORT AND STORAGE

Motors can be transported using any roofed means of transportation, without violent shaking and surges. Lifting of the motors can be done only by the bolt with a lug located on the motor's casing.

Motors must be stored in locations where:

- maximum relative humidity does not exceed 80% at 20°C,
- ambient temperature is between -30°C and +40°C,
- dust, fumes and acrid vapours and other aggressive chemical fumes which can damage the insulation or casing cannot enter,
- no vibrations occur.

It is important to protect processed surfaces of motors in storage from atmospheric impact, by covering them with thick grease or easily removable anti-corrosion paint.

3. SAFE OPERATION RULES

In order to avoid unfortunate accidents while operating the motor, it is important to follow these rules:

- before attempting any regulating operations, inspections or repairs, turn off all power supplies,
- the motor must be installed in accordance with generally applicable rules and regulations,
- in no event can the motor be used without the covers foreseen in its construction,
- motor should be grounded (neutralized) according to current regulations; periodic inspections of the grounding (neutralizing) terminal's condition are necessary
- power cables must be properly secured from being damaged.
- after failures (short circuit or eventually overheating of the winding) in order to ensure that no eventual explosion of fumes - gasses trapped inside the motor occurs, it is necessary, before performing electrical measurements, to carefully air out the motor's interior by dismantling the motor, including taking out the rotor from the stator,

4. MOTOR INSTALLATION

Before installing the motor in place where it will be operated, it is necessary to:

- remove bearing protection (if the motor has such a protection),
- check whether the motor hasn't been damaged mechanically during transport or storage
- measure insulation resistance relative to the casing.

The insulation resistance in a cold state should be at least 5MΩ, and in hot state at least 1000Ω for every 1V of working voltage. If the measured insulation resistance is lower, the motor should be dried out. During drying, create conditions necessary to remove moisture from the winding, i.e. at least, take off the cover of the terminal

box in order to make the exchange of air with the interior of the motor possible. In the process of drying, winding temperature in no case may exceed 80°C.

If the motor is produced with heaters for the winding - the heating elements /55W for motor size 200 ÷ 250; 80W - for motor size 280/ -should be connected at standstill by connecting ~230V to the terminals marked "C,C".

If the motor has no heating elements, the winding can be dried using ~ 24V current connected to any two electric terminals. Drying the stator in e.g. a drier is permitted. The temperature during the drying process cannot exceed 80°C.

The motor should be dried until insulation resistance reaches its required value.

- check the quality of grease in the bearings – if the motor was stored for more than 2 years, replace grease. When changing the kind of grease used, clean the bearings with petrol and dry.

The motor should be installed in such a way that it is easy to access it for inspection and maintenance.

A balanced flexible coupling or a grooved belt pulley should be placed on the motor's shaft neck. In order to do this:

- wash off the protective paint from the shaft neck,
- cover the cleaned shaft neck with grease or oil,
- place the coupling, heated to about 85°C, or the belt pulley on the shaft neck with the help of an appropriate washer and M20 screw, using the threaded opening in the last shaft of the neck, or using a different appropriate tool. When installing the coupling or belt pulley on the shaft, prevent it from hitting motor elements, which can damage the motor's bearings.

After the installation, the motor shaft's axis and the driven appliance must be concentric to at least 0.1mm. At least 1 mm (1.5mm) of space must be kept between the coupling's halves.

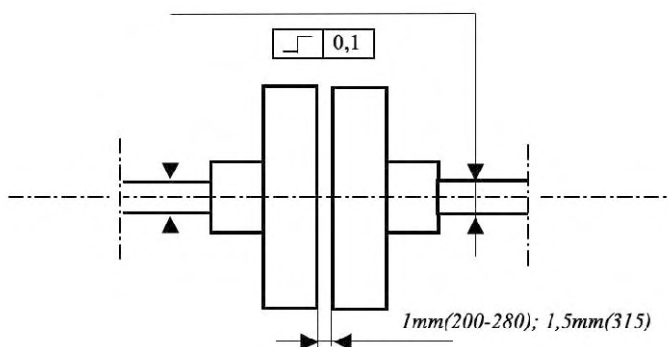

Figure 1. Concentricity of the motor's shaft and the driven appliance.

Peak load on the shaft neck with transverse and axial force may not exceed the limit values specified in the data sheet. In belt drives, avoid an excessive belt pull - it reduced the life of the bearings and overloads the shaft.

5. CONNECTION TO A POWER NETWORK

Before connecting the motor the power network, compare the rating plate data with the network parameters. Markings of the terminals and the connection of the winding is shown in the table containing the connection layout located on the cover of the terminal box .

Motor starting can be performed by direct connecting to the network voltage, or - after removal of the connectors on terminals - using the star - triangle switch.

Thermal protection of stator winding brought out to terminals "1,2" on the terminal strip must be connected with the corresponding input terminals of the resistance relay.

ATTENTION: When checking the temperature sensor circuits, measured voltage should be at max 1.5 V per thermistor.



Motors with winding heaters feature heating tape built into them on the front of the stator winding, with outlets connected to "C,C" terminals on the terminal block - see the table with connection layout. Heating tapes should be powered with ~230V current only when the motor is stopped. During work and during inspection, heating tapes should be disconnected from power supply.

Each motor, in the terminal box, has a suitably marked neutral terminal and grounding terminal on the casing foot or blade flange. The engine should be neutralized and grounded in accordance with regulations.

After connecting all power supply and protection cables, check whether all terminals are tightened securely, check the box's seals and install the terminal box cover.

6. STARTING THE MOTOR

Before starting the motor:

- check the condition of insulation of motor winding /and temperature sensor circuits/ when the measured insulation resistance is too low, the winding must be dried, measurement of insulation resistance should be also performed in the case of longer standstill of the motor,
- check whether a free flow of cooling air to the ventilator is provided,
- check the electric installation, correct operation of the on/off switch and other supporting and securing devices,
- check the tightness of all mounting screws, reliability of the cable connection and all elements having an impact on the motor's protection rating,
- check the quality of the grounding and neutralization,
- check whether the appliance is ready for start-up,
- perform a test start-up.

During the test start-up, you should check:

- the supply voltage,
- current value
- direction of the motor's rotation,
- correct cooling of the motor and correct coupling with the driven appliance,
- whether no excessive vibrations or other improprieties in the work of the motor occur,
- the degree of warming up of engine components such as bearing brackets, bearings, casing.
- correct functioning of start-up devices, control and protection instruments,
- the electrical parameters of the motor and evaluate whether the correct motor type was selected.

Performing the above recommendations and achieving a correct operation of the motor and appliance can be regarded as acceptance of the motor after its installation.

7. OPERATING THE MOTOR

While the motor is in operation, the following should be checked systematically:

- correct operation of the motor,
- correct cooling of the motor,
- correct work of the bearings - there should not be any knocking or whistling,
- whether there are no excessive vibrations of the motor,
- the condition of the motor's coupling with the driven appliance,
- power input shouldn't exceed the nominal value.

The motor should be immediately switched off if any of the following occurs:

- overheating of the casing,
- smoke or smell of burning comes out of the motor or the installation,
- damage to the motor's ventilator,
- damage to the driven appliance,
- if for any other reason further operation of the motor is incorrect or is a threat to its surroundings.

Restart of the motor and the device can take place after the removal of all defects.

8. BEARING MOUNTING AND LUBRICATION OF BEARINGS

Motors have rolling bearings on the drive end and on the non-drive end. The bearing which sets the position of the shaft is the bearing on the non-drive end. The size of bearings for each motor size is given in Table No. 1. The information contained in the data sheet regarding values of acceptable radial and axial forces acting on the shaft neck has been calculated at the assumed life of about 30,000 hours of work alternatively for the ball bearing and the cylindrical roller bearing on the drive end of the motor.

For difficult working conditions and operation with high radial force on the shaft neck, the ball bearing on the drive end can be replaced with a cylindrical roller bearing of the same size.

Motor bearings and bearing chambers are filled with grease. Adding grease is done with the help of a grease pump using grease nipples during operation as far as it is possible. Before applying grease to the bearings, clean the grease nipples.

Table 1 shows the approximate amount of grease when adding or replacing grease for different motor sizes.

Motor size and number of gears	Bearings	Approximate amount of grease per bearing		
		Adding in [g]	Replacing in [g]	
200 2..8	6312 C3	20	100	
225 2..8	6313 C3	23	120	
250 2..8	6315 C3	30	170	
280 2	6315 C3	30	170	
280 4..8	6318 C3	40	260	
315S/M2(A,B)	6315 C3	30	170	
315S/M4..8(A,B)	6318 C3	40	260	
315M2C	6316 C3	35	200	
315M4...8C,D	D	6320 C3	50	300
	ND	6318 C3	40	260
315L2	6317 C3	35	200	
315L4..8(C)	6322 C3	50	300	

Lubrication intervals (in work hours) for **ball bearings** in electric motors working in nominal conditions, in a horizontal position, at ambient temperature up to 40°C

Motor size		3600 t/min	3000 t/min	1800 t/min	1500 t/min	1000-1200 t/min
200	adding grease	1100	1300	1700	2000	3300
200	replacement	5500	8000	14500	17500	23000
225	adding grease	1050	1250	1600	1900	3000
225	replacement	4000	6500	13000	16500	22000
250	adding grease	900	1100	1400	1600	2700
250	replacement	2500	4000	9000	11500	15000
280	adding grease	750	900	1200	1500	2500
280	replacement	2000	3500	6000	8000	12500
315	adding grease	750	900	1200	1500	2500
315	replacement	1900	3200	5900	7600	11800

Remarks:

- 1) Faster aging of grease with increasing temperature must be taken into account. It is recommended to shorten the grease working period by half with every increase of 15°C of operating temperature of grease above 70°C.
- 2) Lubrication intervals for motors working in an upright position should be shortened by half.
- 3) Lubrication intervals for motors working with cylindrical roller bearings should be also shortened by half.

For the lubrication of bearings, RENOLIT H443-HD 88 (motor size 200-250); RENOLIT DURAPLEX Ep2 or RENOLIT LX2 (motor size 280-315) grease have been used/ the type of grease needed is indicated on the motor's rating plate/



9. PERIODIC INSPECTIONS OF THE MOTOR

In order to maintain the motor in full technical efficiency, it is necessary to remove all defects noticed during operation on an ongoing basis. Regardless of the above, it is recommended for each working motor to be subject to periodic inspections, namely:

- minor inspection – every 6 months
- major inspection - every 10 000 hours of work, but not less frequently than every three years

REMARKS:

1. The period between each minor inspection can be longer (to a major inspection) when using monitoring based on controlling the vibrations of bearings and motor's electrical parameters.
2. If the motor operates in conditions with dusting $>800\text{mg}/\text{m}^3$, or relative humidity $>80\%$ or in an aggressive atmosphere, the periods of time between inspections indicated in Table no. 2 must be decreases at least by two

A minor inspection of the motor includes the following actions:

- disconnection of all power conductors,
- visual inspection and cleaning of the motor,
- measuring the resistance of the insulation of the stator winding,
- checking the tightness of all mounting and contact screws,
- inspection of the power cable and protection cables, whether the insulation has not been damaged; or the surfaces of terminals are metallically clean
- checking the level of motor vibrations

Vibrations of the motor coupled with a driven appliance exceeding the permissible level for the motor alone by two times should be treated as excessive and requiring further investigation / driven appliance's requirements or vibration standard for the whole unit should be taken into consideration/. In such a case it is necessary to stop operating the motor, disconnect from the drive and measure the vibrations again on an elastic foundation without the half coupling, with half key. If the intensity of the vibrations exceeds the critical value of required level of vibrations listed in Table no. 2, the motor should be subjected to a mayor inspection.

A minor inspection can reveal a necessity for a further inspection of the motor's construction elements in a dismantled state.

Table no. 2 - Critical intensity of vibrations [mm/s] of motors according to PN-EN 60034-14.

Degree of vibration	Height of the shaft	132 < H ≤ 280	H>280
	Method of mounting	mm/s	mm/s
A	Free suspension	2,2	2,8
	Rigid mounting	1.8	2.3
B	Free suspension	1,1	1.8
	Rigid mounting	0,9	1.5

ATTENTION:

A – standard requirements;

B - lowered vibration level

A mayor **inspection of the motor** includes the following actions:

- disassembly of the motor,
- removal of the rotor,
- inspection of the stator, particularly the condition of the winding,
- measuring the resistance of the insulation of the stator winding,
- inspection of the rotor,
- inspection of bearings, replacement if needed
- replacement of grease
- inspection of the start-up, protection and control instruments.

All defects noticed during the inspection should be removed, and worn out parts replaced with new ones. It is

recommended to renew the protective layers. During the mayor inspection and eventual repairs it is important to maintain the technical requirements defined in the standard indicated on the motor's rating plate. It is recommended to perform the partial test in accordance with the standard PN-E-06755-1.

10. DISASSEMBLY AND ASSEMBLY OF THE MOTOR

In order to remove the rotor from the stator, do the following:

a) on the drive end D:

- remove the key /13/ from the shaft, remove the spring clip which protects the labyrinth sleeve,
- remove the external bearing cover /5/ with the labyrinth sleeve /7/ using two screws screwed into two threaded holes in the bearing cover,
- unscrew the screws securing the bearing bracket D /3/ or 4/ and remove the bracket.

b) on the non-drive end ND:

- unscrew the grease nipple, tube and connector,
- after removing the screws, remove the ventilator /12/,
- remove the screws and pull out the bearing brackets ND /3/ from the casing together with the rotor. After partially pulling out the rotor from the stator, using a lift, carefully pull out the rotor, making sure not to damage the stator winding,

c) disassembly of the bearing bracket ND:

- remove the spring ring which protects the ventilator hub from the shaft,
- remove the ventilator /11/ using the turnbuckle,
- remove the spring ring which protects the labyrinth sleeve from the shaft,
- remove the external bearing cover ND /5/ with the labyrinth sleeve /7/ using two jack bolts M8,
- remove the bearing brackets ND /3/ from the bearing,

d) dismantling of bearings:

- remove the bearing using a turnbuckle.

MOTOR ASSEMBLY is done in the reverse order of the disassembly. Bearings, before being placed on the shaft, should be heated to the temperature of about 80°C. When installing the motor, make sure that the bearing brackets are placed correctly in regard to the location of drain holes for the removal of water from condensation, which should be located in the lowest part of the motor after its installation.

ATTENTION:

Motors during the warranty period and in the post-warranty period are repaired only by the manufacturer or an authorized service centre.



LIST OF MOTOR COMPONENTS

The following list of motor components is included to make ordering of spare parts easier.

Item	Part name	Replacement part	Comments
1.	Stator	-	
2.	Rotor	-	
3.	Bearing bracket	X	
4.	Collar bearing bracket	X	
5.	External bearing cover	X	
6.	Internal bearing cover	X	
7.	Labyrinth sleeve Sleeve with a ring Inner ring	X	
9.	Bearing	part standard	
10.	Grease nipple, tube, connector	part standard	
11.	External ventilator	X	
12.	Ventilator cover	X	
13.	Shaft neck key	part standard	
15.	Electric terminals /terminal board/	X	
16.	Terminal box body	X	
17.	Terminal box cover	X	
18.	Stuffing box	part standard	
19.	Gasket ring	X	
21.	Terminal block /LZ4/	X	
22.	Safety terminal	part standard	
23.	Rating plate	-	

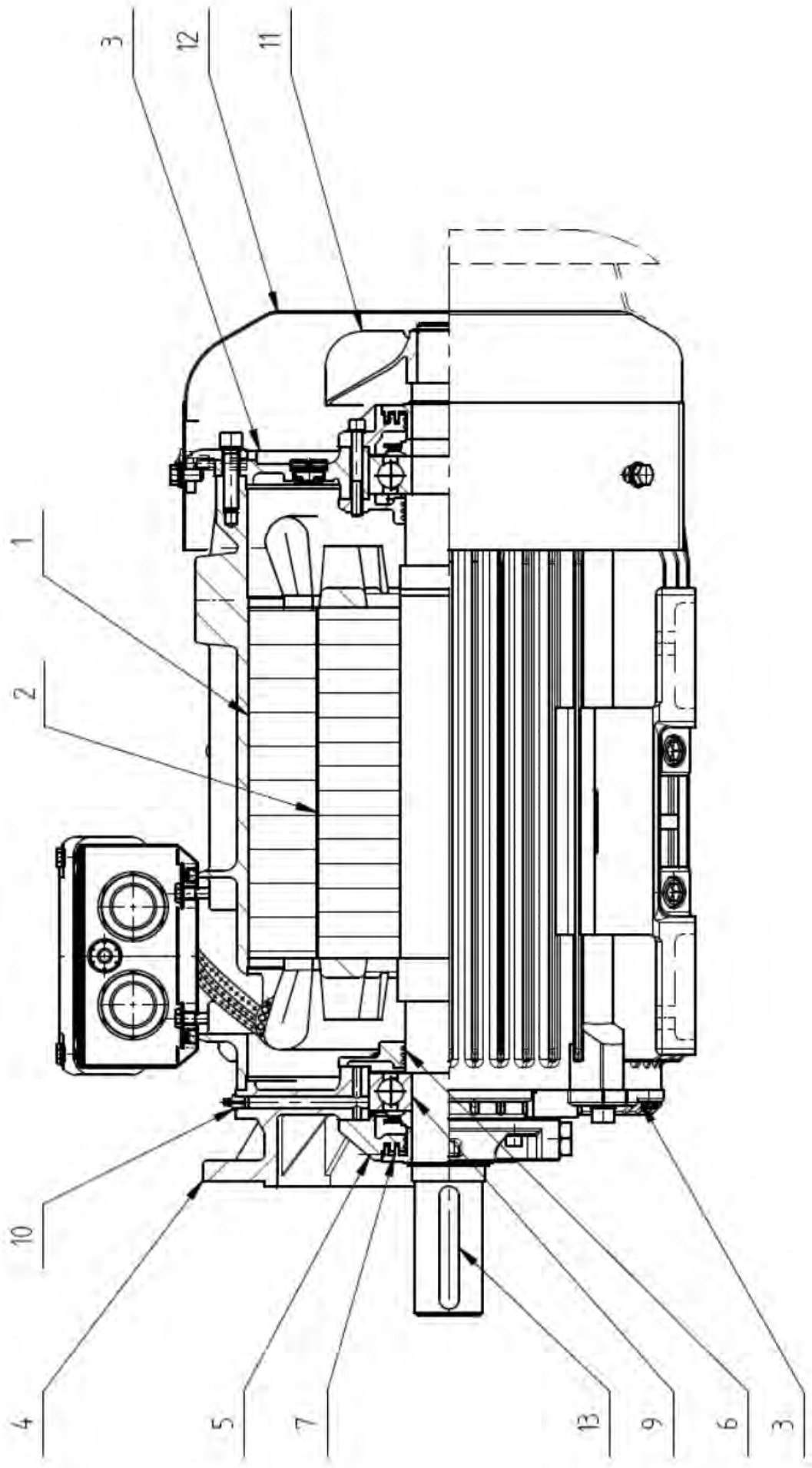

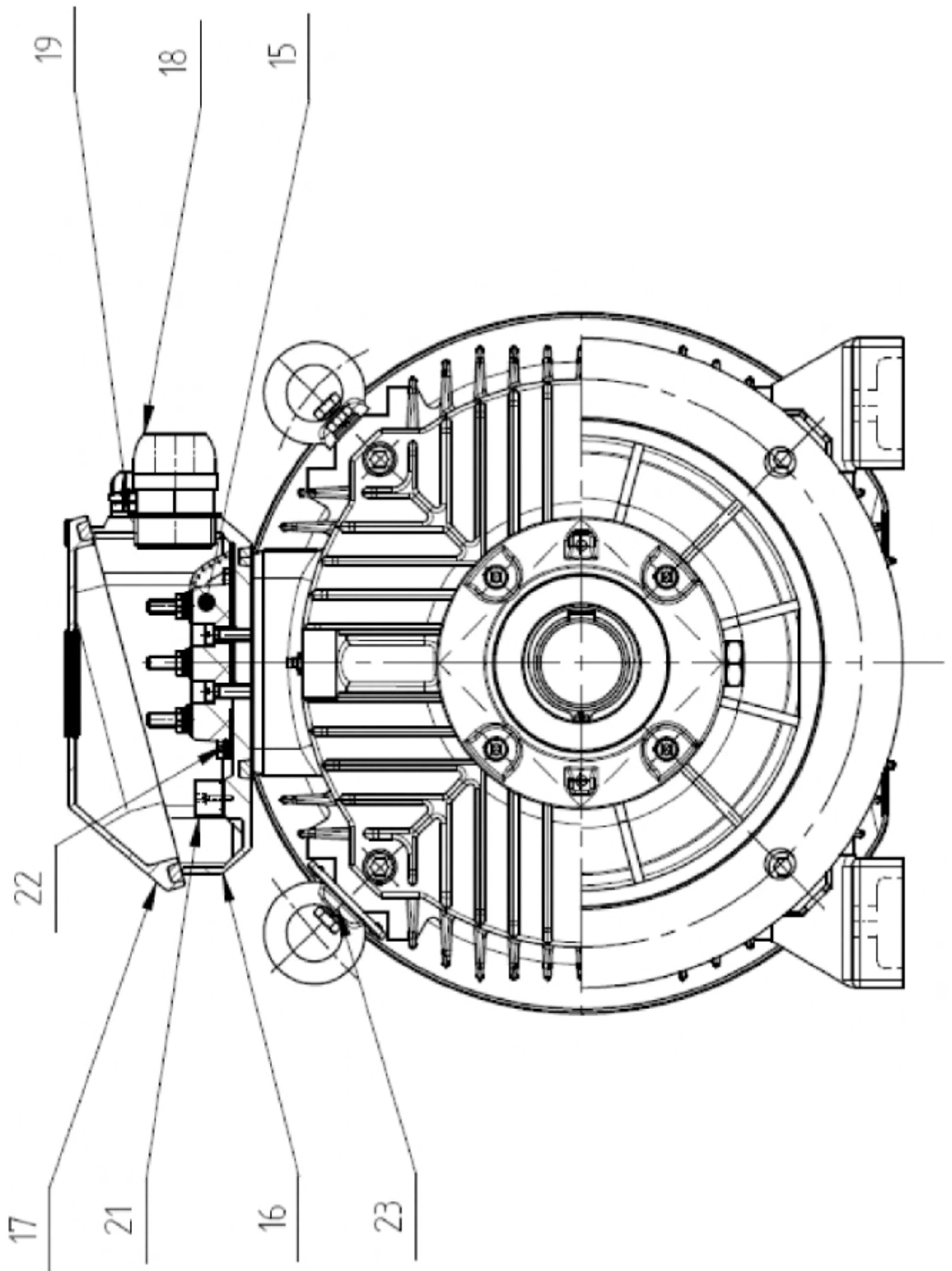

UTILIZATION OF MOTOR'S MATERIALS AFTER THE PERIOD OF OPERATION

Sub-assembly / part name	Method of utilization
casing, bearing brackets and covers, terminal box body, box cover	Scrap iron
Coresh: stator and rotor	Scrap steel (generator sheet) – after removing winding with isolation and melting Al.
Aluminium squirrel cage	Aluminium scrap– after melting
Winding with isolation	Scrap copper (removal and utilization of insulation in a specialized company)
Shaft, sleeves, steel ventilator, ventilator cover, connectors	Scrap steel
Bearings	Scrap steel (after removing grease – grease for utilization in a specialized company)
Rubber parts (seals, rings, etc.)	Utilization in a specialized company
Plastic elements (terminal board, terminal block, ventilator)	Utilization in a specialized company



CANTONI
MOTOR



CANTONI MOTOR S.A.
3 Maja 28
43-400 Cieszyn, Poland
tel.: +48 33 813 87 00
fax: +48 33 813 87 01
motor@cantonigroup.com
www.cantonigroup.com