

CELMA *indukta*

Trójfazowe silniki
wielobiegowe
do wentylatorów
serii 'Q'



Cantoni[®]
GROUP

KATALOG PRODUKTÓW

FABRYKA MASZYN ELEKTRYCZNYCH S.A.

indukta

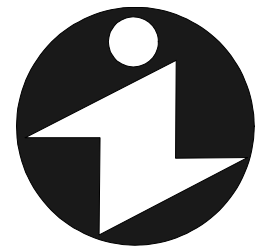

KARTA KATALOGOWA CATALOGUE CARD

Trójfazowe silniki indukcyjne wielobiegowe
z wirnikiem klatkowym do wentylatorów
serii „Q”

Three-phase induction multiple-speed motors
with squirrel-cage rotor for fans
„Q” serie

Cantoni®
GROUP

TELEFON: [48] [33] 827-20-00 ÷ 04
FAX: [48] [33] 827-20-97 ÷ 99
e-mail: indukta@cantonimotor.com.pl
<http://www.indukta.com.pl>

Charakterystyka wykonania:

- moce znamionowe podane są dla pracy S1,
- napięcie znamionowe 380, 400 lub 500 [V],
- częstotliwość napięcia zasilania 50 lub 60 [Hz],
- temperatura otoczenia od -15 do +40[°C],
- wysokość instalowania do 1000 [m] n.p.m.,
- izolacja klasy F,
- stopień ochrony IP 55,
- z jednym czopem końcowym wału wg rysunku wymiarowego,
- skrzynka zaciskowa z dławnicami i tabliczką 6-zaciskową.

Wykonania na życzenia:

- z dwoma walcowymi czopami wału wg rysunku wymiarowego,
- z termistorowymi czujnikami temperatury w czołach uzwojenia,
- przystosowane do pracy w klimacie tropikalnym TH, TA lub MT (w wykonaniu TA lub MT ze względu na podwyższone temperatury otoczenia obowiązuje obniżka mocy znamionowej),
- fabryka wykonuje również silniki różniące się od wykonania podstawowego po uprzednim uzgodnieniu szczegółów konstrukcyjnych i terminów dostaw.

Sposób zamawiania:

- W zamówieniu należy podać pełne określenie typu silnika, moc, prędkość obrotową, napięcie zasilające, układ połączeń, częstotliwość, formę wykonania oraz inne szczegóły niekatalogowego lub specjalnego wykonania.

Features:

- rated output for continuous duty,
- rated voltage 380, 400 or 500 [V],
- frequency 50 or 60 [Hz],
- environment temperature -15 to +40[°C],
- altitude up to 1000 [m] above sea level,
- insulation class F,
- protection degree IP 55,
- one free shaft extension according to dimension drawing,
- terminal box with glands and 6 terminal board with 6 terminals.

Features on request:

- two cylindrical shaft extension according to dimension drawing,
- temperature - sensitive resistors in the winding ends,
- fit for work in tropical climate TH, TA or MT (for TA or MT rated output is decreased due to higher environment temperature),
- factory produces various types of motors but constructional details and delivery time are to be individual agreed.

How to order:

- In the order there must be clearly given: full designation of the motor, rated output, rated speed, rated voltage, phase connection, frequency, mounting form and all other details for non catalogue execution.

PARAMETRY EKSPLOATACYJNE SILNIKÓW PERFORMANCES OF MOTORS

Typ silnika	Połączenie faz		P_n		n_n	η_n	$\cos \varphi_n$	I_{1n} przy nap. znam.			m_{rn}	i_{rn}	m_{maxn}	J	Masa IM B3
Type of motor	Phase connexion		Rated output		Rated speed	Efficiency	Power factor	Full-load amps at			Locked rotor torque	Locked rotor current	Break-down torque	Moment of inertia	Weight IM B3
	-		[kW]	[HP]	[min ⁻¹]	[%]	-	[A] ₃₈₀ v	[A] ₄₀₀ v	[A] ₅₀₀ v	[%]	[%]	[%]	[kgm ²]	[kg]
2p=4/2 $n_s=1500/3000$ obr/min jedno uzwojenie przełączalne rpm=1500/3000 one reconnectional winding															
Sg 160M-4/2Q	4	Δ	3,0	4,0	1470	86	0,82	6,5	6,2	4,9	180	660	310	0,062	102
	2	$\Delta\Delta$	10,5	14,3	2930	84	0,90	21,1	20,0	16,0	210	770	320		
Sg 160L-4/2Q	4	Δ	4,0	5,5	1470	86	0,83	8,5	8,1	6,5	210	710	320	0,076	122
	2	$\Delta\Delta$	15,0	20,0	2940	85	0,91	29,5	28,0	22,4	220	840	330		
Sg 180M-4/2Q	4	Δ	5,0	6,8	1480	87	0,83	10,5	10,0	8,0	220	680	320	0,133	155
	2	$\Delta\Delta$	17,0	22,9	2940	85	0,91	33,4	31,7	25,4	200	740	320		
2p=6/4 $n_s=1000/1500$ obr/min dwa uzwojenia nieprzełączalne rpm=1000/1500 two unreconnectional windings															
Sg 132S-6/4Q	6	Y	1,4	1,9	945	72,0	0,86	3,5	3,3	2,7	120	430	180	0,031	56
	4	Y	4,2	5,8	1430	77,0	0,88	9,4	8,9	7,1	140	510	200		
Sg 132M-6/4Q	6	Y	2,0	2,7	960	76,0	0,83	4,8	4,6	3,6	130	500	200	0,039	67
	4	Y	5,9	8,0	1435	82,0	0,87	12,6	12,0	9,6	150	590	230		
Sg 160M-6/4Q	6	Y	3,3	4,5	980	73,0	0,64	10,7	10,2	8,1	200	660	350	0,069	95
	4	Y	9,4	12,7	1430	82,0	0,89	19,5	18,5	14,8	120	470	190		
Sg 160L-6/4Q	6	Y	4,4	6,0	965	78,0	0,83	10,4	9,9	7,9	160	610	200	0,097	125
	4	Y	12,0	16,3	1425	80,0	0,91	25,5	24,2	19,4	105	460	200		
Sg 180L-6/4Q	6	Y	5,0	6,8	980	81,6	0,88	10,6	10,1	8,1	190	530	210	0,190	165
	4	Y	14,5	19,4	1465	86,7	0,90	28,2	26,8	21,4	210	620	230		
2p=8/4 $n_s=750/1500$ obr/min dwa uzwojenia nieprzełączalne rpm=750/1500 two unreconnectional windings															
Sg 160M-8/4Q	8	Y	1,1	1,5	730	62,0	0,65	4,2	4,0	3,2	130	370	180	0,061	110
	4	Y	8,0	10,7	1460	82,0	0,85	17,5	16,6	13,3	120	520	220		
Sg 160L-8/4Q	8	Y	1,5	2,0	740	52,0	0,54	8,3	7,9	6,3	170	390	280	0,075	130
	4	Y	11,0	15,0	1465	85,0	0,86	22,9	21,8	17,4	130	580	260		
Sg 180L-8/4Q	8	Y	2,2	3,0	740	75,6	0,62	7,1	6,7	5,4	200	460	280	0,155	175
	4	Y	15,0	20,0	1475	88,5	0,89	29,0	27,6	22,0	280	840	340		

Wymiary montażowe silników na łapach Mounting dimensions for foot-mounted motors

Typ Type	A	B	C	D,DA	E,EA	F,FA	GA,GC	H	K
	[mm]								
Sg 132S ...	216	140	89	38k6	80	10h9	41,0	132	12
Sg 132M ...	216	178	89	38k6	80	10h9	41,0	132	12
Sg 160M ...	254	210	108	42k6	110	12h9	45,0	160	15
Sg 160L ...	254	254	108	42k6	110	12h9	45,0	160	15
Sg 180M ...	279	241	121	48k6	110	14h9	51,5	180	15
Sg 180L ...	279	279	121	48k6	110	14h9	51,5	180	15

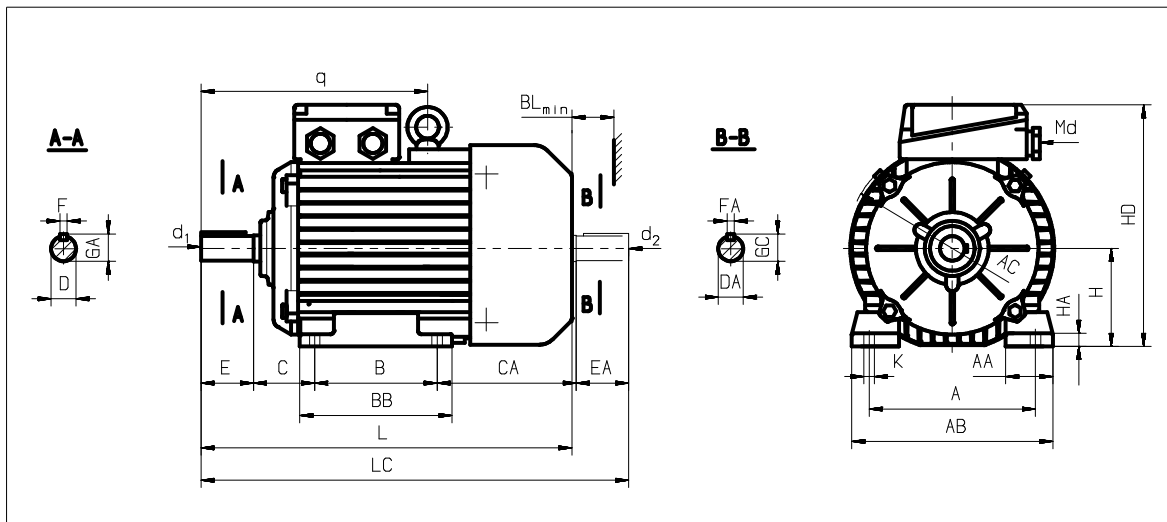

Wymiary gabarytowe silników na łapach Overall dimensions for foot-mounted motors

Typ Type	AA	AB	AC	BB	BL	CA	d1,d2	HA	HD	L	LC	q	Md	Łożysko nr Bearing No
	[mm]													
Sg 132S ...	56	278	274	182	40	160	M12	16	310	463	549	284	M 25 x 1,5	6308 2Z
Sg 132M ...	56	278	274	220	40	160	M12	16	310	501	587	284	M 25 x 1,5	6308 2Z
Sg 160M ...	60	305	323	256	40	200	M16	20	370	612	738	350	M 40 x 1,5	6309 2Z
Sg 160L ...	60	305	323	300	40	200	M16	20	370	656	782	350	M 40 x 1,5	6309 2Z
Sg 180M ...	70	350	360	320	40	243	M16	26	408	705	825	358	M 40 x 1,5	6311 2Z
Sg 180L ...	70	350	360	320	40	205	M16	26	408	705	825	358	M 40 x 1,5	6311 2Z

Wymiar AB dla silników wielkości 132 z łapami odlewanymi wraz z korpusem wynosi 260 mm.

As to motors of size „132” the dimension AB amounts to 260 mm in case the feet are together with frame casted.

Formy wykonania:

■ IM 1001, IM 1011, IM 1031, IM 1051, IM 1061, IM 1071 - wg IEC 34-7, PN-EN 60034-7

■ IM B3, IM B6, IM B7, IM B8, IM V5, IM V6 - wg IEC 34-7, PN-EN 60034-7

Mounting forms:

■ IM 1001, IM 1011, IM 1031, IM 1051, IM 1061, IM 1071 - per IEC 34-7, PN-EN 60034-7

■ IM B3, IM B6, IM B7, IM B8, IM V5, IM V6 - per IEC 34-7, PN-EN 60034-7

Wymiary montażowe silników kołnierzych Mounting dimensions for flange-mounted motors

Typ Type	D,DA	E,EA	F,FA	GA,GC	M	N	P	S	T
	[mm]								
SKg 132S ...	38k6	80	10h9	41.0	265	230j6	300	15	4
SKg 132M ...	38k6	80	10h9	41.0	265	230j6	300	15	4
SKg 160M ...	42k6	110	12h9	45.0	300	250j6	350	19	5
SKg 160L ...	42k6	110	12h9	45.0	300	250j6	350	19	5
SKg 180M ...	48k6	110	14h9	51.5	300	250j6	350	19	5
SKg 180L ...	48k6	110	14h9	51.5	300	250j6	350	19	5

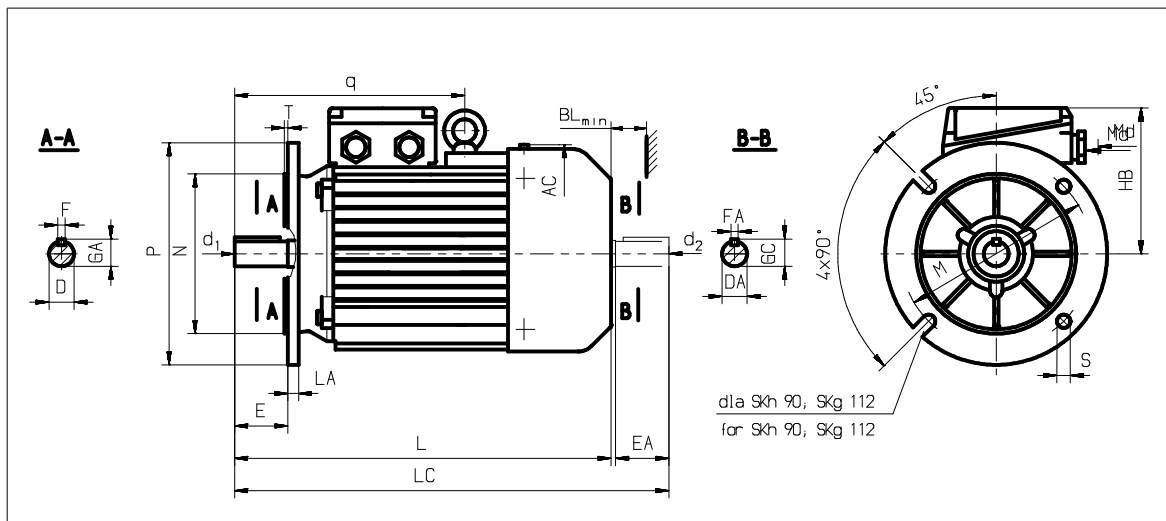

Wymiary gabarytowe silników kołnierzych Overall dimensions for flange-mounted motors

Typ Type	AC	BL	d1,d1	HB	L	LA	LC	q	Md	Łożysko nr Bearing No
	[mm]									
SKg 132S ...	274	40	M12	178	463	12	549	284	M 25 x 1,5	6308 2Z
SKg 132M ...	274	40	M12	178	501	12	587	284	M 25 x 1,5	6308 2Z
SKg 160M ...	323	40	M16	210	612	13	738	350	M 40 x 1,5	6309 2Z
SKg 160L ...	323	40	M16	210	656	13	782	350	M 40 x 1,5	6309 2Z
SKg 180M ...	360	40	M16	228	705	13	825	358	M 40 x 1,5	6311 2Z
SKg 180L ...	360	40	M16	228	705	13	825	358	M 40 x 1,5	6311 2Z

Formy wykonania:

- IM 3001, IM 3011, IM 3031 - wg IEC 34-7, PN-EN 60034-7
- IM B5, IM V1, IM V3 - wg IEC 34-7, PN-EN 60034-7

Mounting forms:

- IM 3001, IM 3011, IM 3031 - per IEC 34-7, PN-EN 60034-7
- IM B5, IM V1, IM V3 - per IEC 34-7, PN-EN 60034-7

Wymiary montażowe silników kołnierzowych na łapach Mounting dimensions for foot-flange-mounted motors

Typ Type	A	B	C	D,DA	E,EA	F,FA	GA,GC	H	K	M	N	P	S	T
	[mm]													
SLg 132S ...	216	140	89	38k6	80	10h9	41,0	132	12	265	230j6	300	15	4
SLg 132M ...	216	178	89	38k6	80	10h9	41,0	132	12	265	230j6	300	15	4
SLg 160M ...	254	210	108	42k6	110	12h9	45,0	160	15	300	250j6	350	19	5
SLg 160L ...	254	254	108	42k6	110	12h9	45,0	160	15	300	250j6	350	19	5
SLg 180M ...	279	241	121	48k6	110	14h9	51,5	180	15	300	250j6	350	19	5
SLg 180L ...	279	279	121	48k6	110	14h9	51,5	180	15	300	250j6	350	19	5

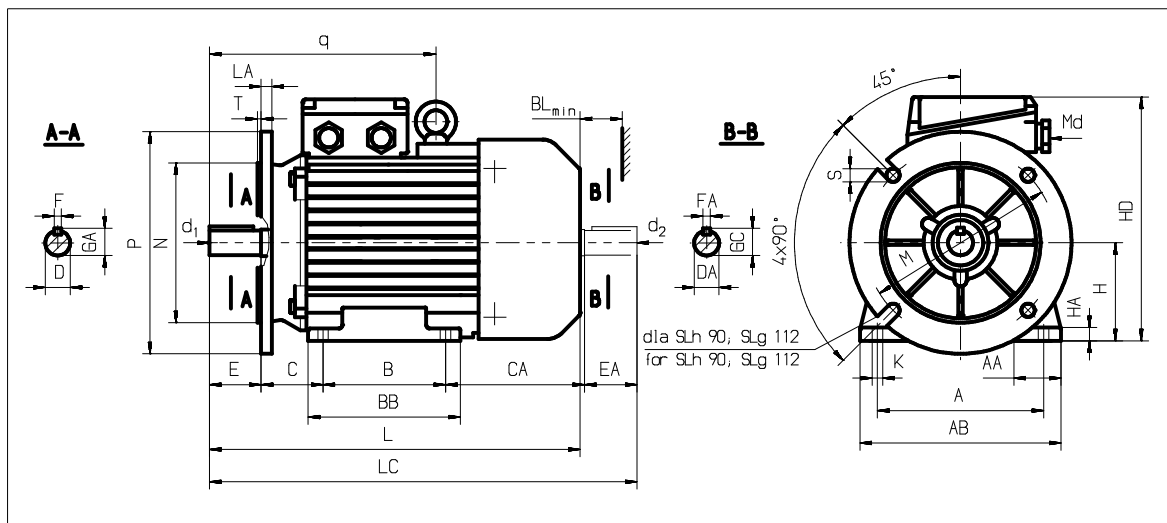

Wymiary gabarytowe silników kołnierzowych na łapach Overall dimensions for foot-flange-mounted motors

Typ Type	AA	AB	BB	BL	CA	d1,d2	HA	HD	L	LA	LC	q	Md	Łożyisko nr Bearing No
	[mm]													
SLg 132S ...	56	278	182	40	160	M12	16	310	463	12	549	284	M 25 x 1,5	6308 2Z
SLg 132M ...	56	278	220	40	160	M12	16	310	501	12	587	284	M 25 x 1,5	6308 2Z
SLg 160M ...	60	305	256	40	200	M16	20	370	612	13	738	350	M 40 x 1,5	6309 2Z
SLg 160L ...	60	305	300	40	200	M16	20	370	656	13	782	350	M 40 x 1,5	6309 2Z
SLg 180M ...	70	350	320	40	243	M16	26	408	705	13	825	358	M 40 x 1,5	6311 2Z
SLg 180L ...	70	350	320	40	205	M16	26	408	705	13	825	358	M 40 x 1,5	6311 2Z

Wymiar AB dla silników wielkości 132 z łapami odlewanymi wraz z korpusem wynosi 260 mm.

As to motors of size „132” the dimension AB amounts to 260 mm in case the feet are together with frame casted.

Formy wykonania:

- IM 2001, IM 2011, IM 2031 - wg IEC 34-7, PN-EN 60034-7
- IM B35, IM V15, IM V36 - wg IEC 34-7, PN-EN 60034-7

Mounting forms:

- IM 2001, IM 2011, IM 2031 - per IEC 34-7, PN-EN 60034-7
- IM B35, IM V15, IM V36 - per IEC 34-7, PN-EN 60034-7